

Cushion hanger kit, for 3×φ11mm+3×φ30mm cable

- Manufactured by EPDM & stainless steel
- Excellent for outdoor use
- Universal fixing design on wall, pole, angle steel
- Hardware kit included

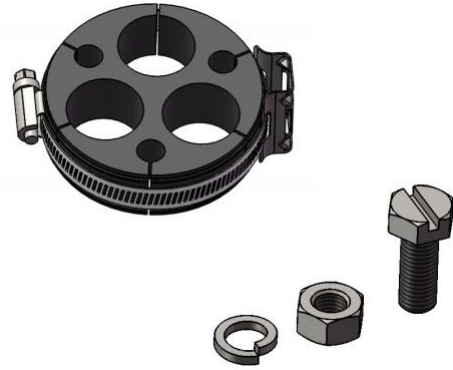

Product Classification

Material Code	6006800
Part Number	-
Status	Active
Detail description	Cushion hanger kit for 3×φ11mm+3×φ30mm cable + 3/8"×1" bolt + 3/8"nut + 3/8"spring washer

General Specifications

Material	EPDM rubber & SS304 Hardware kit
Cable type	Corrugated Elliptical Waveguide Smoothwall
Cable size	3×φ11mm+3×φ30mm
Color	Black

Dimensions

Height	38 mm 1.5 in
Length	93 mm 3.66 in
Nominal size	3×φ11mm+3×φ30mm

Environmental Specifications

UV resistance	≥1000Hours, based on ISO 4892-3
---------------	---------------------------------

Packaging and Weights

Bag,width	210 mm 8.27 in
Bag,length	370 mm 14.57 in
Included	Cushion hanger kit (iInstallation hardware included)
Packaging quantity and UOM	Kit of 5
Weight, gross	0.86 kg 1.90 lb

Certifications and Compliance

For more information, please visit:
www.maxdao.com



©Copyright 2023 Maxdao Inc. All rights reserved.

The information contained herein is subject to change without notice. We reserve the right to make technical changes or modify the contents of this document without prior notice.

Revised: Feb 20, 2023

Public

DATASHEET

MAXDAO

ISO 9001:2015

Designed, manufactured and/or distributed under this
quality management system

ROHS

Compliant

DOC#ITM04-01, Version:A/2, Updated:02/21/2023

For more information, please visit:
www.maxdao.com



©Copyright 2023 Maxdao Inc. All rights reserved.

The information contained herein is subject to change without notice. We reserve the right to make technical changes or modify the contents of this document without prior notice.

Revised:Feb 20, 2023

Public

Page 2 of 2